

8350 V-TRAVEL

DESIGN BY
JUSTUS KOLBERG

Geared towards international airports, shopping centres, lobbies as well as waiting and recreation areas in large commercial and public buildings – 8350 V-Travel is the newest generation of Public Seating. These stand-alone seat islands, characterized by a slender design language, are an architectural eye-catcher. Its excellent comfort level in combination with its capacity for up to 8 persons invite you to take a seat to relax and rest a moment.



CONTENT

Variations	2
Product data	4
Materials, finishes	6
Fire prevention, quality, sustainability	7



After having studied industrial design in Kiel, Justus Kolberg started working for Italian design studios. Upon his return to Germany, he designed several successful seating series for Wiege Entwicklungsgesellschaft. He is a freelancer since 1997. Many internationally renowned furniture manufacturers value his intelligent designs. As does Kusch+Co by giving him the opportunity to develop his special passion for contract seating.

VARIATIONS

8350 V-TRAVEL

Characterised by their unique design language, these seat islands function both as an eye-catcher and a point of rest. Ideally suited for the shopping areas in airports, for shopping centres and lobbies as well as the waiting areas in health care facilities and medical practices. Thanks to the upholstery volume, these slender benches offer a high comfort level.



CIRCLE



SQUARE



LONG OVAL



RECTANGLE

8350 V-TRAVEL



Circle

8350/5



Square

8355/5

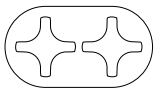

Long oval

8360/5

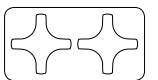

Rectangle

8365/5

PRODUCT DATA

8350 V-TRAVEL

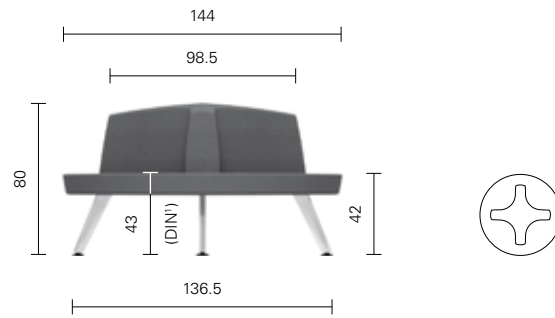

Weight: 35.0 kg

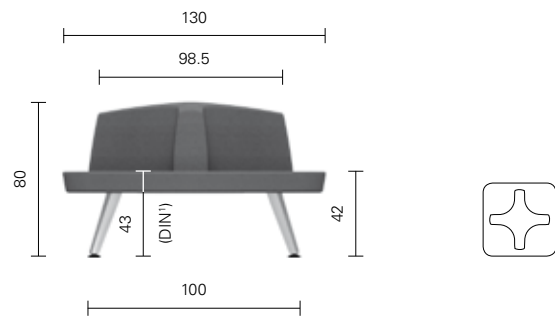

Weight: 35.0 kg

ACCESSORIES

- Plastic glides, black grey
- Plastic glides, nonskid, black grey
- Floor fixation elements invisibly incorporated in leg/glide, either through screws or with adhesives



¹The DIN seat height was determined acc. to DIN EN 1335-1, i.e. the seat height measured by means of a measuring device at the position of the ischial tuberosity (sitting bones) after having placed a load of 50 kg on the half width of the seat.

8350 V-TRAVEL

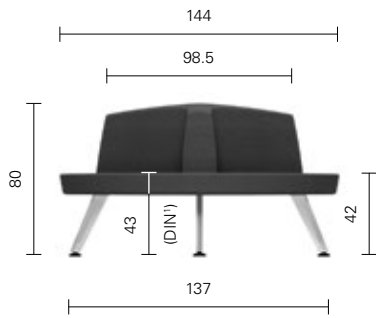

Weight: 75.0 kg

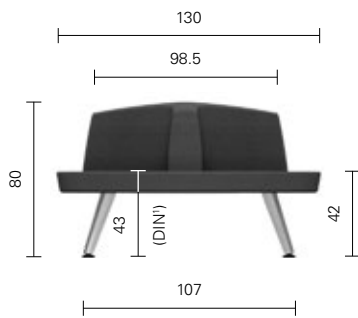
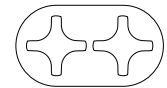
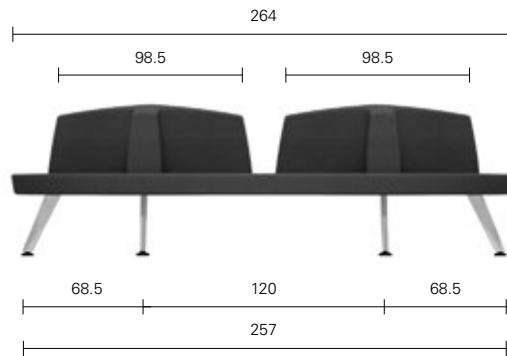

Weight: 65.0 kg

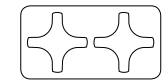
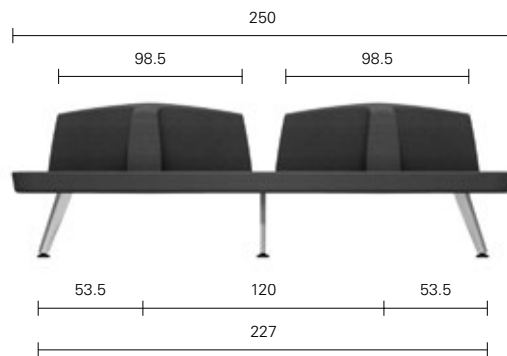

POWER AND DATA

- Power socket incorporated in the back, individual configuration possible
- Power and data module for two oppositely positioned seats with country-specific power sockets or double USB



MATERIALS, FINISHES

8350 V-TRAVEL

MATERIALS

- Inner core made of beech plywood, entirely upholstered
- Back entirely upholstered
- Die-cast aluminium legs

UPHOLSTERY

- Seat/back entirely upholstered, fabric from standard collection
- Optionally available with upholstery with flame retardant foam resp. flame retardant foam and fireproof fabric

FRAME

- Aluminium legs, polished or powder coated acc. to standard collection



Polished or powder coated aluminium

POWDER COATING

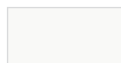

RAL 9003
signal white



RAL 9006
white aluminium
(metallic effect)



silver aluminium
(metallic effect)



silver 98
(metallic effect)



DB 703
iron mica



RAL 9005
jet black



silk

FIRE PREVENTION

QUALITY, SUSTAINABILITY EXCERPT

FIRE PREVENTION

Depending on the environment, contract seating has to be able to fulfil very specific requirements. Interior designers and planners sometimes have to clear difficult hurdles: such as exacting fire prevention regulations. Kusch+Co has worked out individual solutions:

UPHOLSTERY

The upholstery is optionally available with flame retardant foam. In addition, it is available with the Kusch+Co Fire Prevention Concept, consisting of a special fabric "flamline" (approved by the building authorities and conforms to DIN 4102 A2 non-flammable) between the upholstery foam and the fabric.

This concept achieves four life-saving objectives. The seating:

- is self-extinguishing
- reduces the smoke development
- prevents an incipient fire from spreading out
- does not turn into an additional ignition source.

Test reports in compliance with national and international standards document the laboratory fire tests conducted on different series finished with a wide variety of materials.

With regard to the upholstery, e.g. with leather, artificial leather as well as many textile fabrics, or to our unupholstered variations featuring a plywood, laminated or plastic seat shell, most of our series meet the following standards:

- Germany: DIN 66084 P-a
- France: NF D 60-013
- Great Britain: BS 5852 Crib 5
- Italy: UNI 9176
- Europe: EN 1021 part 1/2

Please contact us if you wish to receive the test reports.

Please contact us to receive further information.

QUALITY

Our environmental and quality management systems are certified acc. to DIN EN ISO 14001 and to DIN EN ISO 9001. External audits as well as our in-house laboratory safeguard our quality level.

The benches of series 8350 V-Travel meet the following standards:

- DIN EN 16139 Level 1 (strength)
(Δ DIN EN 13761)
- DIN EN 16139 Level 2 (strength)
(Δ DIN EN 15373 Level 3)
- DIN EN 1022 (stability)

The benches of series 8350 V-Travel with power and data modules are tested acc. to:

- DIN VDE 0701-0702 June 2008
- and meet the European Directives
- 73/23/EEC; 93/68/EEC (Low Voltage Directive)
 - 89/336/EEC; 93/68/EEC (EMC Directive).

In our capacity as a DIN EN ISO 9001 certified company, we are authorised to test in our own laboratory whether our products meet the GS requirements for Tested Product Safety and issue a Declaration of Conformity equivalent to a GS sign.

We happily make these Declarations of Conformity as well as our brochure "Mission Statement Quality" providing detailed information on our test procedures available to you – please contact us.



SUSTAINABILITY

Kusch+Co products stand for long life cycles and optimum recyclability. From the first design drafts of a new product, we take all environmental-relevant components and production processes into consideration, ranging from the materials selection and the design all the way to the manufacturing processes which also contribute towards our sustainable energy balance.

